

DVD-5 Pit Art Label Specifications				
Europe	DVD	EDS004	Issue 1	Sep 2003

## Electronic artwork requirements for on-body pit art labels

Pit art uses the laser mastering process to “engrave” mirror surface graphics on to the frosted unused surface of a DVD-5. Only electronic graphic files can be accepted for imaging due to the nature of the pit art process.

Design: Black areas will appear as a mirror surface, and white areas as the frosted surface on the disc.

DVD 5 Pit Art

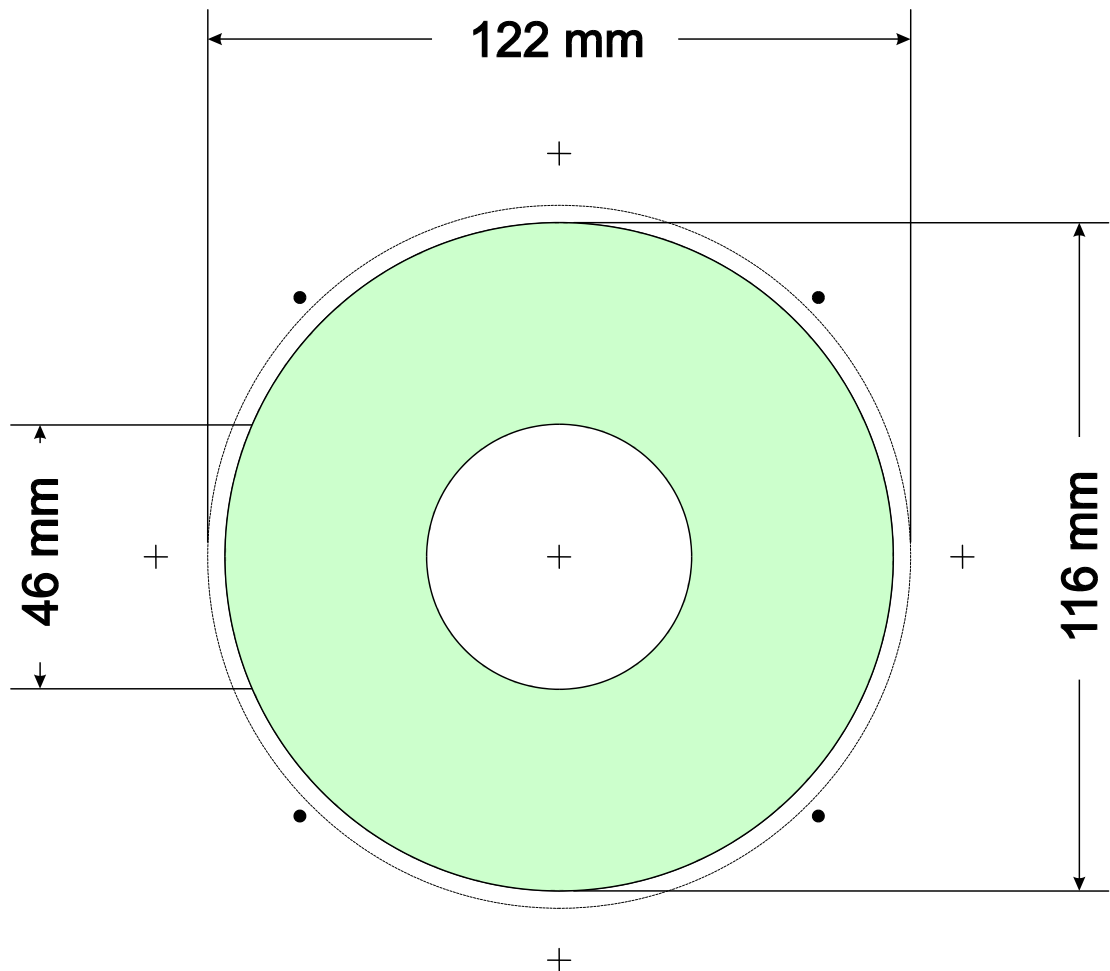

- Projects should be single colour graphics files with line screen resolutions to 200 lpi.
- Proofing: labels can be proofed for content only, using high contrast monochrome proofs, e.g. laser proofs, film or contact bromide prints.
- Registration marks: to locate your graphic, please use the standard crosshairs and a circle 122mm diameter, at 0.25 point rule size on your graphic image.
- Please identify artwork with catalogue number and title
- If a bitmap is used, it should have a minimum resolution of 1200dpi.